

# 496M/496P

## 2,0 t

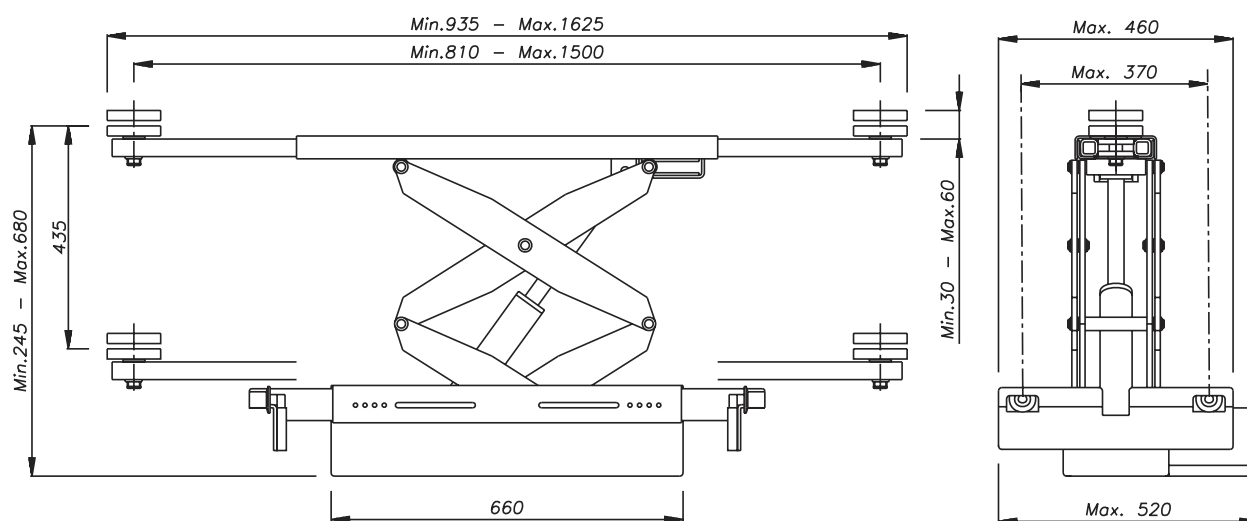

Dati tecnici - Technical data - Caractéristiques techniques - Technische Eigenschaften

Portata • Capacity • Capacité • Hubkraft	2.000 kg
Spostamento vert. del carico • Lifting height • Hauteur de levée • Hubhöhe	435 mm
Estensione min.(bracci chiusi) • Min. extension (arms retracted) • Extension min. des bras (bras rentrés) • Min. Aufnahmebreite (Arme voll eingefahren)	935 mm
Estensione min.(bracci aperti) • Min. extension (arms extracted) • Extension max. des bras (bras sortis) • Min. Aufnahmebreite (Arme voll ausgefahren)	1.625 mm
Passo delle ruote di scorrimento min. • Wheel base min. • Pas des roulettes • Achsabstand der Laufrollen	725 + 860 mm
Passo delle ruote di scorrimento max. • Wheel base max. • Pas des roulettes • Achsabstand der Laufrollen, max.	1.105 + 1.200 mm
Peso della traversa • Weight • Poids • Gewicht	135 kg

## Opzioni - Optionals - Options - Sonderzubehör



- Kit appoggi per traversa
- Support kit for jacking beam
- Jeu de supports pour traverse
- Stützesatz für Achsfreiheber

L1166



- Estensioni per tamponi di sollevamento
- Lifting pad extensions
- Rallonges pour tampons de levage
- Hubspindelverlängerungen

• 60 mm L1198

• 100 mm L1277



### WERATHER INTERNATIONAL S.p.A.

Via F. Brunelleschi, 12 - 42100 Cadè (RE) Italy

Tel. ++39 0522 9431 - ++39 346 98 37 325 - ++39 346 98 37 443 - Fax ++39 0522 941997

[www.wertherint.com](http://www.wertherint.com) - e-mail: [sales@wertherint.com](mailto:sales@wertherint.com)

Il fabbricante, nell'ambito del costante miglioramento dei propri prodotti, si riserva il diritto di apportare modifiche senza preavviso. - The company reserves the right to introduce improvements in design or specification without prior notice. - Der Hersteller behält sich das Recht vor, im Zuge der technischen Weiterentwicklung, technische Eigenschaften ohne Vorankündigung zu ändern. - Le fabricant dans le but d'améliorer constamment ses produits, se réserve le droit d'apporter des modifications sans préavis. - La compañía Werther se reserva de todos modos el derecho de aportar todas las modificaciones que considera necesarias para mejorar la estética o el funcionamiento de los productos, sin tener la obligación de avisar de ello.

# 496/3M-496/3P **3,0 t**



Traverse idraulica  
Hydraulic jacking beams  
Traverses hydrauliques  
Hydraulische Achsfreiheber

Modelli disponibili / Available versions / Versions disponibles / Lieferbare Ausführungen

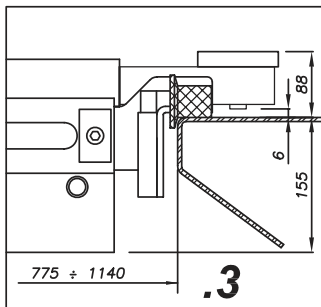

450 LT, 450 N/5, 450 ATLT

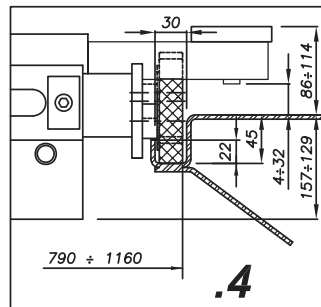

443, 442 LP, 450-3D  
SATURNUS 36R,  
SATURNUS 45/50 (NGL, ATGL)

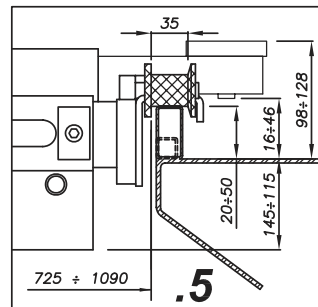

430, 430 BL, 435, 436,  
450 AT

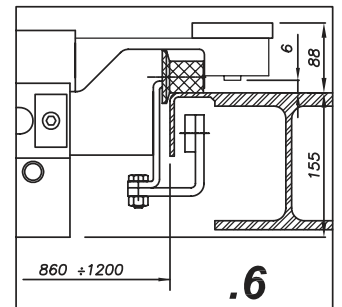

460

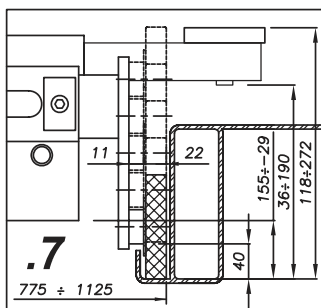

20/2/07\_R0

VARI  
VARIOUS  
PLUSIÉURS  
VERSCHIEDENE

 Sollevatore/Pont élévateur/Lift/Säulen

 Rullo/Galet/Roller/Rolle

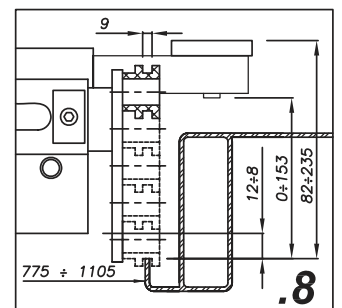
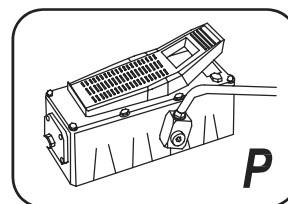
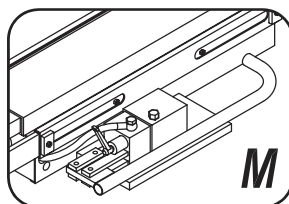

VARI  
VARIOUS  
PLUSIÉURS  
VERSCHIEDENE

# WERTHER



# 496/3M-496/3P

# 3,0 t

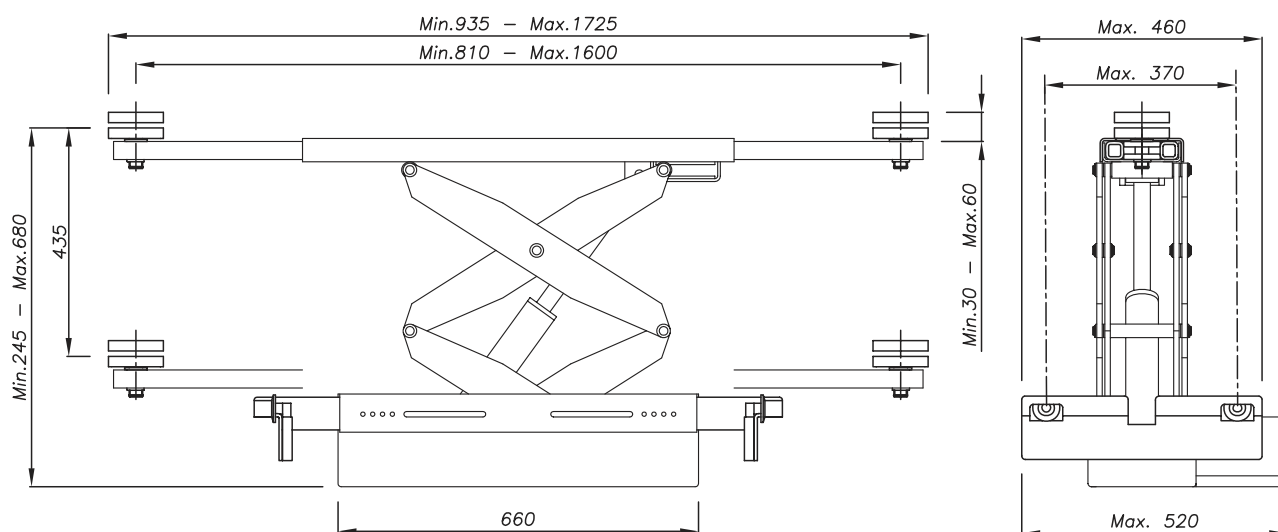

## Dati tecnici - Technical data - Caractéristiques techniques - Technische Eigenschaften

Portata • Capacity • Capacité • Hubkraft	3.000 kg
Spostamento vert. del carico • Lifting height • Hauteur de levée • Hubhöhe	435 mm
Estensione min.(bracci chiusi) • Min. extension (arms retracted) • Extension min. des bras (bras rentrés) • Min. Aufnahmebreite (Arme voll eingefahren)	935 mm
Estensione min.(bracci aperti) • Min. extension (arms extracted) • Extension max. des bras (bras sortis) • Min. Aufnahmebreite (Arme voll ausgefahren)	1.725 mm
Passo delle ruote di scorrimento min. • Wheel base min. • Pas des roulettes • Achsabstand der Laufrollen	775 ÷ 860 mm
Passo delle ruote di scorrimento max. • Wheel base max. • Pas des roulettes • Achsabstand der Laufrollen, max.	1.105 ÷ 1.200 mm
Peso della traversa • Weight • Poids • Gewicht	150 kg

## Opzioni - Optionals - Options - Sonderzubehör



- Kit appoggi per traversa
- Support kit for jacking beam
- Jeu de supports pour traverse
- Stützesatz für Achsfreiheber

L1166



- Estensioni per tamponi di sollevamento
- Lifting pad extensions
- Rallonges pour tampons de levage
- Hubspindelverlängerungen

• 60 mm L1198

• 100 mm L1277



### WERATHER INTERNATIONAL S.p.A.

Via F. Brunelleschi, 12 - 42100 Cadè (RE) Italy

Tel. ++39 0522 9431 - ++39 346 98 37 325 - ++39 346 98 37 443 - Fax ++39 0522 941997

www.wertherint.com - e-mail: sales@wertherint.com

Il fabbricante, nell'ambito del costante miglioramento dei propri prodotti, si riserva il diritto di apportare modifiche senza preavviso. - The company reserves the right to introduce improvements in design or specification without prior notice. - Der Hersteller behält sich das Recht vor, im Zuge der technischen Weiterentwicklung, technische Eigenschaften ohne Vorankündigung zu ändern. - Le fabricant dans le but d'améliorer constamment ses produits, se réserve le droit d'apporter des modifications sans préavis. - La compañía Werther se reserva de todos modos el derecho de aportar todas las modificaciones que considera necesarias para mejorar la estética o el funcionamiento de los productos, sin tener la obligación de avisar de ello.