

■ VENUS SA 20 ■ VENUS SA 20 IT



Smontagomme superautomatico con colonna ribaltabile pneumaticamente per ruote di auto, moto e veicoli industriali leggeri da 10" a 22".

Super automatic tyre changer with air operated tilting of column for car, motorcycle and van wheels. Rim diameter 10" to 22".

Démonte pneus super-automatique avec colonne basculante pneumatiquement pour roues de voitures, motos et véhicules industriels légers de 10" à 22" de diamètre.

Vollautomatische Reifenmontiermaschine mit pneumatisch kippbarer Säule für Autos, Motorräder und leichte Nutzfahrzeuge mit 10" bis 22" Felgendurchmesser.



WERTHER



VENUS SA 20 ■ VENUS SA 20 IT

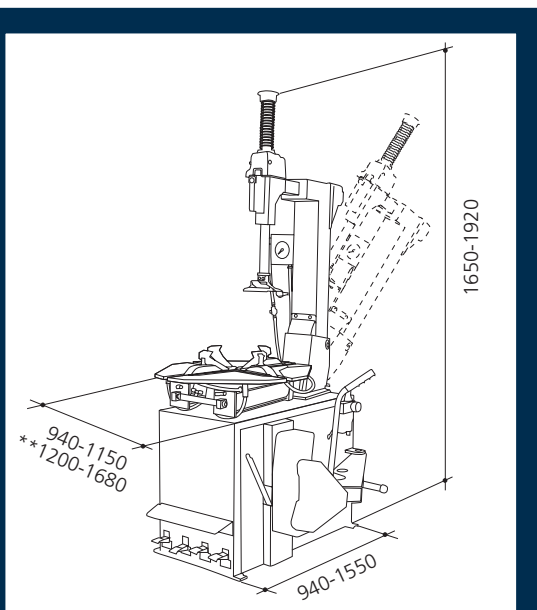

IT

Dispositivo di gonfiaggio per pneumatici senza camera d'aria (tubeless). Con serbatoio INTERNO da 14 lt.
 Quick tubeless tyres inflation system with 14 lt. INTERNAL air receiver
 Système gonflage pour pneus sans chambre à air (tubeless) avec réservoir INTERNE de 14 l.
 Schnelleinblasvorrichtung für schlauchlose Reifen mit INNENLIEGENDEM 14 lt-Tank



Dati tecnici - Technical data - Caractéristiques techniques - Technische Eigenschaften

Bloccaggio cerchio dall'esterno	Rim clamping from outside	Serrage jante de l'extérieur	Aussenaufspannung der Felge	10"-20"
Bloccaggio cerchio dall'interno	Rim clamping from inside	Serrage jante de l'intérieur	Innenaufspannung der Felge	12"-22"
Diametro max. ruota	Max. wheel diameter	Diamètre max. roue	Max. Raddurchmesser	940 mm
Larghezza max. ruota	Max. wheel width	Largeur max. roue	Max. Radbreite	280 mm
Forza cilindro stallonatore	Bead-breaking cylinder force	Force du vérin détalonneur	Kraft des Abdrückzylinders	2000 kg
Pressione di servizio	Operating pressure	Pression de service	Betriebsdruck	8 - 10 bar
Alimentazione	Power supply	Alimentation	Versorgungsspannung	230/400V 50 Hz - 3 ph
Potenza motore	Motor power	Puissance moteur	Motorleistung	0,55 kW

Opzioni - Optionals - Options - Sonderzubehör

Serie (4) morsetti ruote moto 8" - 23"
 Set of (4) motorcycle wheel adaptors 8" - 23"
 Jeu de mors (4) pour roues moto 8" - 23"
 Satz (4) Aufspannadapter für Motorradräder 8" - 23"

H908



Serie (4) protezioni in plastica per cerchi in lega
 Set (4) of plastic jaw pads for protecting alloy rims
 Jeu (4) de protections en plastique pour jantes en alliage
 Satz (4) Kunststoff-Schutzkappen für Alufelgen

A2262



A0146



Anello per secchio portagrasso
 Holder for grease bucket
 Anneau pour godet à graisse
 Haltering für Schmiermittelkessel

H910

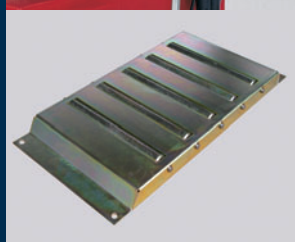

Rulliera confort per orientamento ruota in fase di stallonatura
 Comfort roller board
 Support auxiliaire à rouleaux pour faciliter le détalonnage
 Rollenbahn zur Erleichterung des Abdrückvorgangs



WERATHER INTERNATIONAL S.p.A.

Via F. Brunelleschi, 12 - 42040 Cadè (RE) Italy - Tel. ++39 0522 9431 - Fax ++39 0522 941997
www.wertherint.com - e-mail: sales@wertherint.com

Il fabbricante, nell'ambito del costante miglioramento dei propri prodotti, si riserva il diritto di apportare modifiche senza preavviso. - The company reserves the right to introduce improvements in design or specification without prior notice. - Der Hersteller behält sich das Recht vor, im Zuge der technischen Weiterentwicklung, technische Eigenschaften ohne Vorankündigung zu ändern. - Le fabricant dans le but d'améliorer constamment ses produits, se réserve le droit d'apporter des modifications sans préavis. - La compañía Werther se reserva de todos modos el derecho de aportar todas las modificaciones que considera necesarias para mejorar la estética o el funcionamiento de los productos, sin tener la obligación de avisar de ello.